

Ambi-GASS™

Gas Analysis Sampling System Operation and Maintenance Manual



PERMA PURE INC.

TABLE OF CONTENTS

1	Introduction	3
2	Theory of Operation	
2.1	Filtration	3
2.2	Automatic Filter Drain (optional)	3
2.3	Manual Filter Drain (optional)	4
2.4	Sample Pump (optional)	4
2.5	Ammonia Scrubber (optional)	4
2.6	Nafion Dryer	4
2.7	Purge Air Dryer (optional)	5
3	Installation	
3.1	Mounting	5
3.2	Electrical Connection	5
3.2.1	Alarm Relays	6
3.3	Sample Connection	6
3.4	Purge Connection	
3.4.1	Instrument Air	6
3.4.2	Heatless Dryer	6
4	Control System Operation	
4.1	Dryer Purge Air Control	7
4.2	Safety Interlocks	7
5	Start-Up Procedure	
5.1	Setup Check	7
5.2	Automatic Filter Drain Control	7
5.3	Purge Air Eductor Adjustment	8
6	Maintenance	
6.1	Filters	9
6.2	Dryers	9
6.3	Fuse Replacement	10
	Appendix A – Specifications	11
	Appendix B – Drawings	12

TABLE OF FIGURES

1-1	Ambi-GASS System Overview	12
2-1	Filter Flow Pattern for Filtration and Coalescing	13
2-2	Ambi-GASS Flow Schematic	13
2-3	Perma Pure Nafion Membrane Dryer Schematic	14
3-1	Terminal Block for Power Connections	14
3-2	3 Pole Terminal Block for Alarm Connections	14
5-1	DIP Switch Layout	15
6-1	FF-250 Filter	15



Thank you for purchasing sample gas conditioning equipment from Perma Pure Inc. We want your new sample gas conditioning equipment to operate safely. Anyone who installs or uses this equipment should read this publication before installing or operating this equipment.

To minimize the risk of potential safety problems, you should follow all applicable local and national codes that regulate the installation and operation of your equipment. These codes vary from area to area and usually change with time. It is your responsibility to determine which codes should be followed and to verify the equipment, installation and operation is in compliance with the latest revision of these codes.

At a minimum, you should follow all applicable sections of the National Fire Code, National Electrical Code, and the codes of the National Electrical Manufacturer's Association (NEMA). There may be local regulatory or government offices that can also help determine which codes and standards are necessary for safe installation and operation.

Equipment damage or serious personal injury can result from the failure to follow all applicable codes and standards. We do not guarantee the products described in this publication are suitable for your particular application, nor do we assume any responsibility for your system design, installation or operation. This product should not be operated in any manner that is inconsistent with its intended use.

If you have any questions concerning the installation or operation of this equipment, or you need additional information, please call us at 1-800-337-3662.

This publication is based on information that was available at the time it was printed. At Perma Pure we constantly strive to improve our products and services, so we reserve the right to make changes to the products and/or publications at any time without notice and without any obligation. This publication may also discuss features that may not be available in certain revisions of the product.

Nafion® and Teflon® are registered trademarks of EI DuPont de Nemours
Copyright 1996, Perma Pure Inc. All Rights Reserved

1 INTRODUCTION

Perma Pure Ambi-GASS sample pre-conditioning systems are designed to prepare gas samples for analysis.

The Ambi-GASS system will remove:

Particulate
Mists
Water vapor

Without removing the compounds being monitored.

Figure 1-1 of appendix B gives a general overview of an Ambi-GASS system

Standard Features Include:

- Filter – Particulate and/or Coalescing
- Perma Pure Nafion gas Dryer
- Dryer Purge Flow Controls

Options:

- Sample Pump
- Filter Drain
- Ammonia Scrubber

2 THEORY OF OPERATION

2.1 Filtration - The first step in conditioning the sample is to filter out particulate and aerosols. This is accomplished by passing the sample through a 1 μ filter. The standard filter included with the Ambi-GASS system has a borosilicate glass filter element with a fluorocarbon binder. This element is disposable and will withstand high sample temperatures. In addition to removing particulate, the filter also coalesces liquid aerosols and droplets.

Two flow patterns are possible with this filter:

1. Installed with the flow passing from the outside to the inside of the element, the element will act as a particulate filter only. The advantage of this installation is that collected particulate will build up on the outside surface of the element, allowing visual inspection of the element's condition.
2. Installed with the flow passing from the inside of the element to the outside, the element will act as both a particulate and a coalescing filter. Figure 2-1 of appendix B details the flow through the filter housing and element.

2.2 Automatic Filter Drain (optional) - If coalescing is anticipated, the system should be fitted with an automatic filter drain to periodically remove collected liquid mists. In most cases these mists will be acid mists. The automatic drain will operate in a vacuum or pressurized system. In a vacuum configuration, the collected liquid is withdrawn from the filter drain port by a strong vacuum created by an eductor expanding compressed air through a venturi. This is done in cycles, which are controlled by an adjustable digital timer that switches a solenoid valve and controlling the compressed air supply. In pressurized applications, a vacuum is not needed to withdraw the sample, so no eductor is required. In this case the condensate withdraw is

directly controlled by the solenoid valve. Cycle times can be varied and will be dependent on the amount of liquid present in the sample.

2.3 Manual Filter Drain / Catchpot (optional) – In a pressurized system where very little coalescing is anticipated, the system can be fitted with a manual filter drain. This would consist of a toggle valve placed with the drain line. When the valve is opened pressure from the system will force the condensate to be expelled. This option should only be used when very little coalescing is anticipated and the system is checked on a frequent basis. For Portable systems, a PFA Teflon Catchpot assembly can be used on either vacuum or pressure applications. It consists of a small threaded top container that will hold about ½ fl. oz. of liquid. *It is intended to hold a small amount of acid that may be coalesced from the sample stream. It is not intended to hold water condensate. Gloves should be worn when removing the container for disposal of acid.*

2.4 Sample Pump (optional) - Perma Pure can supply a gas sample pump to draw the sample and supply it to the analyzers. The standard pump supplies up to 5 liters per minute of sample however, a larger pump can be supplied for special applications. The typical pump location is between the filter and the ammonia scrubber (when installed).

2.5 Ammonia Scrubber (optional) - The optional ammonia scrubbing canister must be used when ammonia or urea is used for the purpose of lowering NO_x levels or at any time ammonia is present in the sample stream. Ammonia salts can deposit in the dryer tubes if not removed and cause permanent loss of drying efficiency. The ammonia scrubber consists of a polysulfone and 316 SST housing filled with phosphoric acid impregnated berl saddles. These berl saddles will require periodic replacement at a frequency dependent on the inlet ammonia concentration.

2.6 Nafion® Dryer - The Perma Pure Nafion membrane dryer is installed downstream of the filter. As the sample enters the dryer, the flow splits into a number of small diameter Nafion membrane tubes arranged in a parallel bundle (see Figure 2-3 appendix B). After the sample enters one of these tubes it comes in contact with the Nafion membrane walls. The membrane selectively removes water vapor from the sample by a process of permeation distillation. Water vapor travels through the tubing walls driven by the difference in partial water vapor pressure on the opposing sides of the membrane. As the sample flows from inlet to outlet water is continually removed, reducing the sample dew point as it travels through the dryer. Dry purge gas enters the dryer at the sample outlet end and performs two functions.

1. Provides a medium for the water vapor from the sample to be carried away.
2. Creates the temperature gradient along the length of the dryer.

The ambient purge air enters the dryer at the sample outlet keeping that portion of the dryer cooled. This counter current flow is required to produce a temperature gradient along the length of the dryer. This gradient allows for both rapid vapor removal and decreased final dew point.

It is important that the dryer removes water in the vapor state only to avoid the problems that arise when the membrane comes in contact with liquid water. If liquid water is introduced into the dryer, efficiency will decline and the dryer could fail to perform altogether. The tubing elongates approximately 10% over its dry length when saturated with liquid water causing the tubing to kink inside the dryer housing, reducing the drying. Nafion dryers will operate most

efficiently when a portion of the dryer is heated to prevent the sample from condensing out liquid water.

Nafion transfers water vapor with a higher efficiency at elevated temperatures. However, at these temperatures it tends to hold more water in the membrane, reducing its ability to lower the final dew point temperature. This amount of bound water is relative to the temperature of the dryer and gives the membrane a corresponding water vapor pressure. When the water vapor pressure of the sample arrives at equilibrium with the water vapor pressure of the membrane, the transfer stops. For instance, a dryer at room temperature will bind an amount of water equivalent to a dew point of about -45°C. As the temperature of the membrane in the dryer increases, the amount of bound water also increases. This increase is equivalent to about ¾°C dew point per 1°C temperature increase above 25°C. So, if the entire length of the dryer was heated to 65°C (40°C over room temperature), the lowest possible dew point achievable by the dryer would be -15°C (30°C above the -45°C minimum at room temperature). For this reason the dryer should be kept at the lowest temperature possible without causing the sample to condense. Since the sample dew point constantly drops as it travels through the dryer, a temperature gradient that is just above the sample dew point is the most desirable. This can be achieved by cooling the sample outlet with purge air where the sample dew point is the lowest. Efficiency throughout the dryer is achieved by using this process.

2.7 Purge Air Dryer (optional) - If 40°C dewpoint or drier purge air is not available, a heatless air dryer can be installed in the Ambi-GASS to dry a compressed air supply. The heatless dryer requires an inlet air pressure of 60 to 100 psig. The outlet of the heatless dryer will be connected to the standard purge gas flow controls. The purge controls would then be operated as usual. Operation of the heatless dryer is fully automatic and continuous, and should not require maintenance for several years.

3 INSTALLATION

3.1 Mounting

1. Arrange system on a vertical surface.
2. Place mounting feet on each corner of the enclosure with the slotted end protruding at a 45° angle from the enclosure.
3. Drop the mounting screw in from the top and tighten into foot.

NOTE: Unit should be shielded from direct rain and snow. Do not install outdoors if temperature will fall below -10°C.

3.2 Electrical Connection

Ambi-GASS MODEL #	110 VAC	220 VAC
1214, 1412	Standard power cord and plug	Cord with pigtail wires

1228, 1235	Connect the power supply line to the terminal block located on the bottom of the control enclosure just inside the ½” conduit hub. See Figure 3-1 of appendix B for color coding.
------------	-----------------------------------------------------------------------------------------------------------------------------------------------------------------------------------

3.2.1 Alarm Relays:

Systems with the SIS2 or SIVS2 option, allowing for the connection of external alarm equipment, will have an additional 3 pole terminal block that will allow for field wiring of the alarm relays (see Figure 3-2). The relay contacts are rated at 250 VAC, 3A resistive.

NOTE: It is recommended that a fused disconnect (not provided) be installed in the power line coming into the system. This will allow power to be shut off before performing any maintenance or service procedures

3.3 Sample Connection

1. Connect the sample line directly to the bulkhead fitting mounted through the enclosure wall
2. Connect the sample outlet port of the Ambi-GASS to the sample line running to the analyzer

3.4 Purge Connection

3.4.1 Instrument Air

➤ ***The purge air supply must be of instrument grade with a dew point no higher than -40°C.***

1. Connect the purge air line to the air inlet port using the ¼” NPT female fitting
2. Set the instrument /compressed air supply pressure regulator between 30 and 100 psig

3.4.2 Heatless Dryer (Optional)

1. Connect the purge air line to the air inlet port using the ¼” NPT female fitting
2. Set the air pressure regulator between 60 and 100 psig
3. There will be an additional ¼” female NPT bulkhead fitting on the bottom of the enclosure for the heatless dryer purge air exhaust. This will be humid air, and can be vented to atmosphere or piped to a remote location.

4 CONTROL SYSTEM OPERATION

4.1 Dryer Purge Air Control

Purge air to the dryer is controlled by the regulator/flowmeter combination on the control panel. The pressure setting is not critical and should be determined by the vacuum required to drain the filter as mentioned in the filter/drain setting section.

1. With optional filter drain – Set pressure to approx. 10 psig.
2. Without the filter drain – Set pressure to approx. 20 psig
3. Adjust the purge air flow to 1 1/2 to 2 times the sample flow before start-up.

4.2 Safety Interlocks (SIS2 / SIVS2) (optional)

Systems equipped with the SIVS2 interlock option automatically shut off the sample pump or the sample control valve in the event of low purge airflow in the system. To accomplish this, a differential pressure switch in the purge air inlet senses the flow of purge air and energizes a relay. This relay then sends power to the sample valve and the valve will open and allow sample flow. Under normal operating conditions the safety relay will remain energized (Normally open contacts will close, and remain closed, when the system is operating normally).

The SIS2 option operates in a manner similar to the SISV2 except the SIS2 does not include a sample control valve. If a pump is installed in the system it will be wired into the interlock as above. In both the SIS2 and SIVS2 options, the alarm relay may be field wired to initiate an external alarm.

5 START-UP PROCEDURE

5.1 Setup Check

1. Check electrical, sample, purge and drain connections have been made.
2. Turn on compressed air to the system.

5.2 Automatic Filter Drain Control (optional)

The automatic filter drain is controlled by a repeat-cycle-timer that operates a solenoid valve. There are two DIP switches located on the timing device that controls the drain and cycle times. (See Figure 5-1 of appendix B)

Standard factory setting is to drain for 0.1 minute once every 24 hours.

<u>Drain time</u> (left DIP switch)	0.1 minutes (1 st switch on – all others off) to 102.3 minutes (all switches on)
<u>Cycle time</u> (right DIP switch)	0.25 hours (1 st switch on – all others off) to 255.75 hours (all switches on)

1. Adjust the purge air pressure regulator to about 15 psig.

When the sample is under a **vacuum**, the purge air regulator will control the air pressure to the eductor of the automatic filter drain. The regulator must be set to provide ample vacuum to remove the filter condensate but not excessive enough to cause an interruption in the sample flow to the analyzers.

Systems under **positive pressure** will allow for the condensate drain flow to be directly controlled by a solenoid valve. When the solenoid valve is actuated (opened) the positive pressure in the filter housing purges the condensate out of the system through the drain line.

2. Initially adjust the DIP switches on the drain timer to drain for 6 seconds every 24 hours. The time on the switches is additive. So, the left switch should have only the top 0.1 min. switch in the on position and the right switch should have the 8 and 16 hr. switches in the on position. These time periods may need further adjustment after the system has been in operation for a while.

5.3 Purge Air Eductor Adjustment (optional)

1. Adjust the eductor regulator until the vacuum gage reads about 2-5 inches of mercury. ***This will need to be re-adjusted each time changes are made to the purge flow rate or purge pressure.*** The eductor will provide the desired vacuum inside of the dryer shell at this vacuum rate to compensate for any small vacuum that the sample may be under. This is done to prevent the membrane tubes from collapsing under the pressure of the purge air.

6

MAINTENANCE

6.1 Filters

If the system is fitted with a pre-filter, it should be checked regularly to ensure that the element is in good condition. If the element appears to be dirty or begins to cause a flow restriction in the system, it should be replaced.

6.1.1 FF-150, FF-200, and FF-275 Element Replacement:

1. Loosen the bolt assembly.
2. Swing the yoke up to allow access to the element.
3. By hand, loosen the element which is threaded into the top piece
4. Inspect the flat gaskets on the FF-200 and FF-275 or “O”-rings on the FF-150 each time the filter element is changed.
5. Apply Teflon tape the threads at the top of the element and screw the element into the filter top.
6. Place the flat gasket on the bottom piece and then place the glass shell on the bottom piece.
7. While holding the other flat gasket on the filter top piece, put the glass shell/bottom piece assembly into place.
8. Swing the yoke back to center and tighten the knob while being sure that the bolt tip is centered in the indentation in the filter bottom piece.

6.1.2 FF-250 Filter Element Replacement

1. Loosen the bolt on the bottom of the filter
2. Gently pull apart the assembly and remove the old element
3. Place a new element into the grooves in the top and bottom of the housing.
4. When re-assembling the housing, be sure to inspect the “O”-rings on the top and bottom pieces and on the center bolt
5. Install the glass shell onto the bottom piece
6. Place the new element in the groove in the bottom piece. Be sure that the element is seated correctly and parallel to the glass shell.
7. Carefully mate the bottom assembly onto the top piece. A slight twisting motion may be required to allow the shell to slip over the “O”-ring seal.
8. Visually make sure that the element is seated correctly in the top groove.
9. Replace the bolt through the hole in the bottom piece and screw clockwise into the top piece. Do not to over-tighten the center bolt or damage may occur. It should be just tight enough as to not vibrate loose. Over-tightening will not help the filter to seal.

6.2 Dryers

Under normal conditions Perma Pure dryers require little maintenance and can last for several years. However, if there is no pre-filter and the tubing becomes clogged or saturated with water, the dryer may require cleaning or repair. When disassembling the dryer note that the end fittings on the PD-SERIES dryer can be easily rotated on the shell tube. This rotation should be avoided to prevent twisting the membrane tubes inside the shell.

To Disassemble the Dryer:

1. Hold the coupling and shell nut with one hand. Then, with the other hand, loosen and remove the end nut.
2. The end of the dryer element assembly and “O” ring seals will now be visible. With your fingertips, check to be sure that the dryer element is free to spin inside the coupling by rotating it back and forth about 10 degrees in either direction.
3. Loosen the shell nut connecting the coupling to the shell tube.
4. To completely disassemble the dryer, repeat the above procedure for the other end.
5. Once both end nuts have been removed, put on a pair of clean lightweight gloves to protect the membrane tubing from skin oils that can contaminate the surface and reduce drying efficiency.
6. Gently pull one end of the element out of the coupling enough to remove the “O” ring seals.
7. Gently pull the element out of the housing from the opposite end.

When assembling the dryer, reverse the procedure. Be sure that the element is centered in the housing before installing the end nuts. ***When connecting any fitting to the purge ports of the dryer, be sure not to tighten the threaded fitting more than 5 turns. Additional turns may cause the fitting to damage the element header just below.***

6.3 Fuse Replacement - The fuse is located on or in the control enclosure.

To remove the fuse:

1. Turn the cap marked “FUSE” counter-clockwise $\frac{1}{4}$ turn and the fuse holder will come out.
2. Remove the blown fuse and replace with one of equal amperage rating. The standard fuse is a BUSS type AGC or equivalent.
3. After installing the correct replacement fuse, re-install the fuse holder by pressing inward and twisting $\frac{1}{4}$ turn clockwise.

APPENDIX A - Specifications

MAXIMUM SAMPLE FLOW RATE:	0 TO 20 LITERS/MIN
MAXIMUM GAS SAMPLE WATER VAPOR CONTENT:	NON CONDENSING AT AMBIENT TEMPERATURE
SOLUBLE GAS REMOVAL RATES:	NO, NO2 0% loss SO2 0% loss CO, CO2 0% loss H2S, HCl 0% loss
MAXIMUM GAS SAMPLE INLET PRESSURE:	80 PSIG
MINIMUM GAS SAMPLE INLET PRESSURE:	5" H2O VACUUM
GAS SAMPLE INLET FITTINGS:	1/4" or 3/8" TUBING FITTINGS
GAS SAMPLE OUTLET FITTINGS:	1/4" or 3/8" TUBING FITTINGS
AIR REQUIREMENTS:	PURGE AIR -40°C DEW POINT MAXIMUM ONE (1) CFM
ELECTRICAL REQUIREMENTS:	110/220VAC, 50/60 Hz, 3.0A/1.5A (330 WATTS)
FUSE:	3 AMP BUSS TYPE AGC OR EQUIVALENT
ENCLOSURE:	NEMA 4X, FIBERGLASS WITH POLYCARBONATE COVER
DIMENSIONS:	15" HIGH X 13" WIDE X 7" DEEP
WEIGHT:	20 LBS
OPERATING ENVIRONMENT:	-20°C TO 40°C AMBIENT TEMP. 0 TO 95% R.H.

APPENDIX B - Drawings

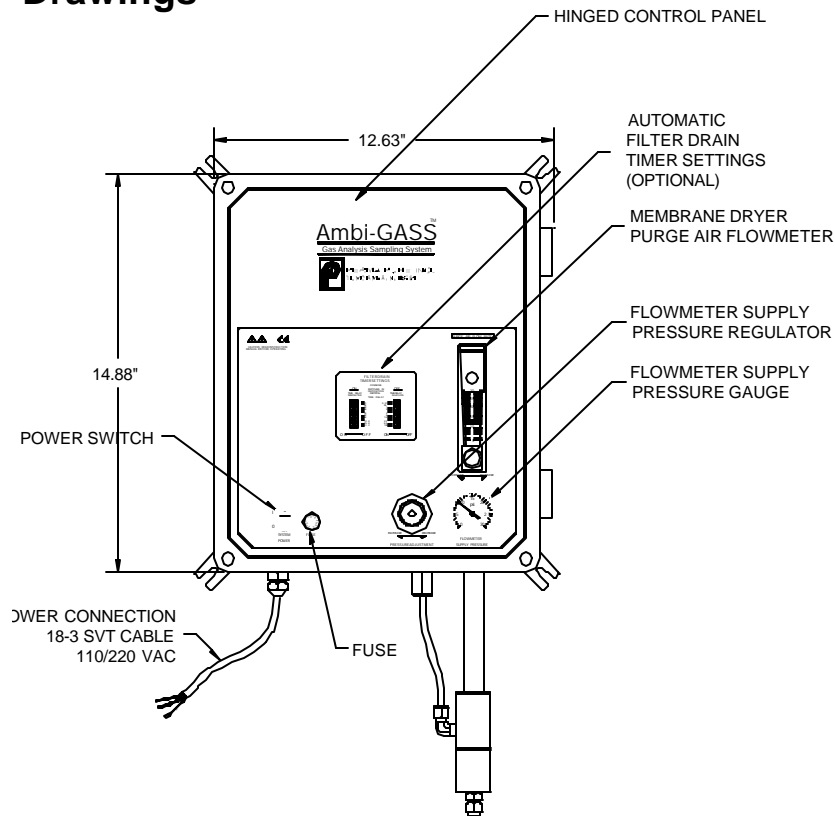

Figure 1-1 AG-1214 System Control Panel Overview

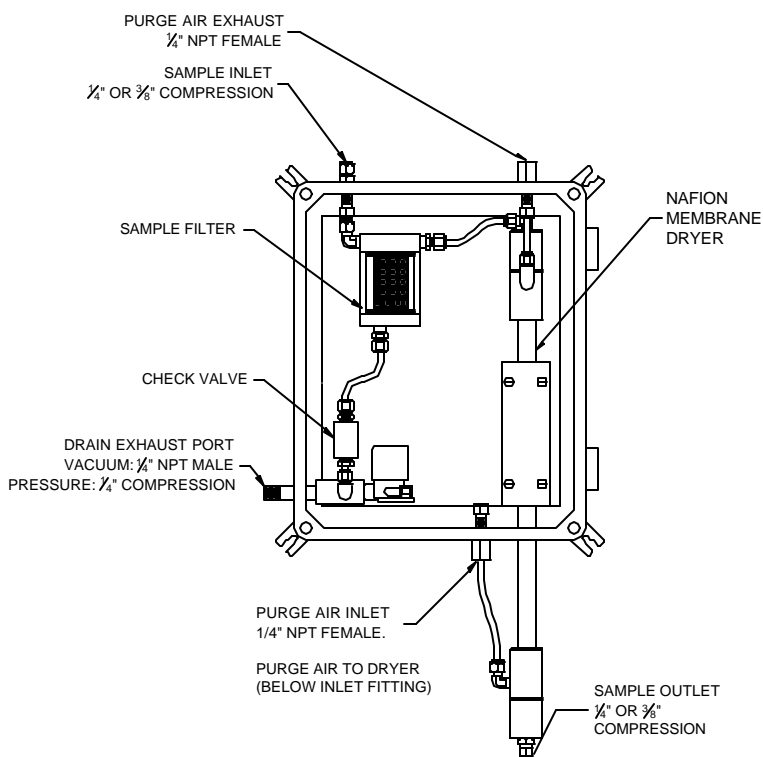

Figure 1-1 AG-1214 System Interior Overview

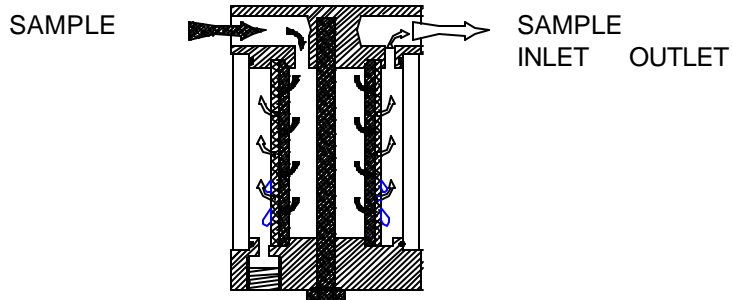

Figure 2-1 Filter Flow Pattern for Filtration and Coalescing

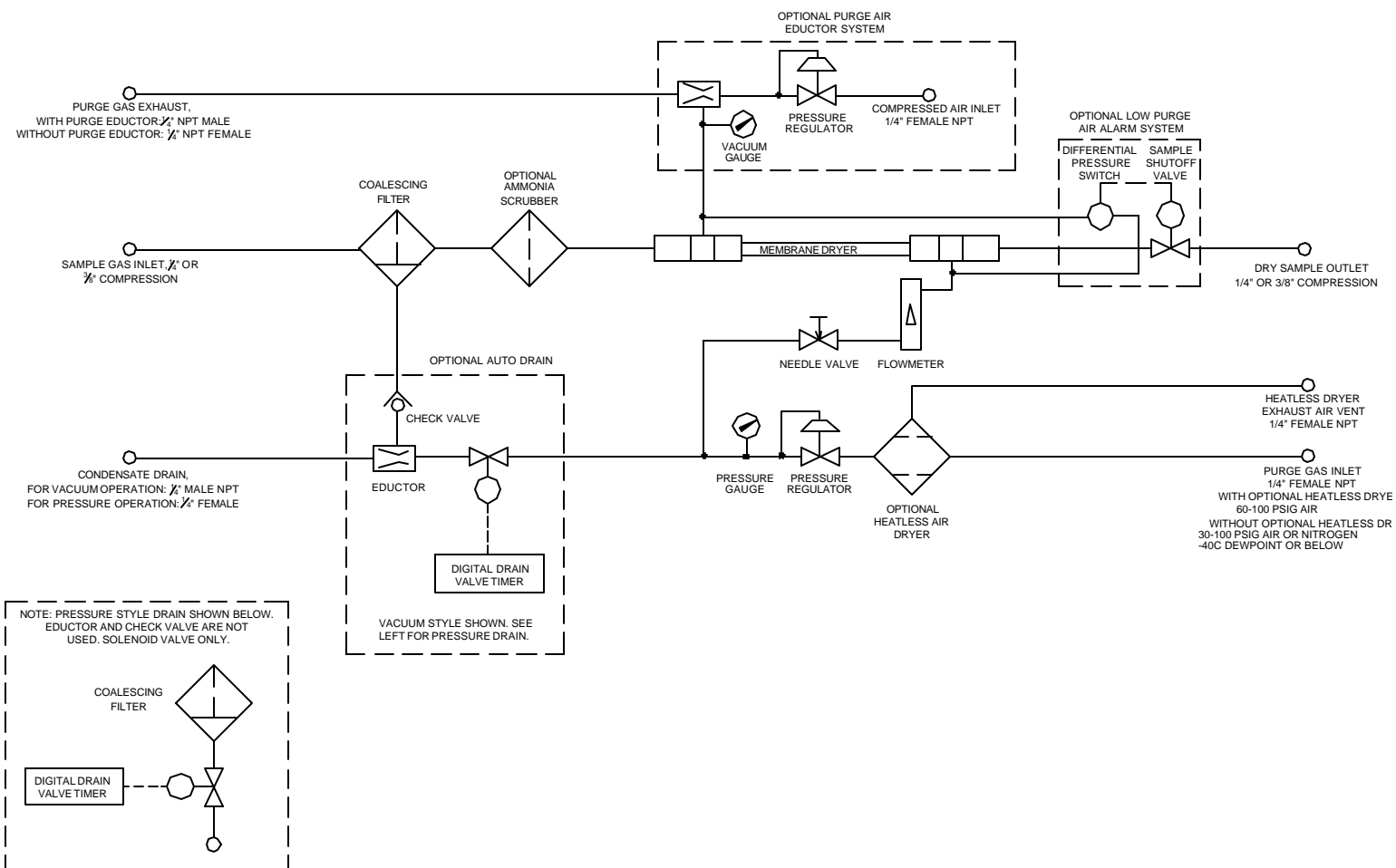

Figure 2-2 Ambi-GASS Flow Schematic

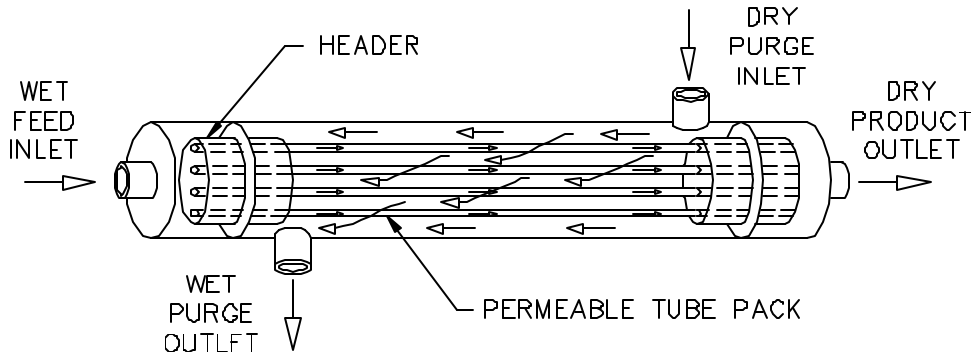

Figure 2-3 Perma Pure Nafion Membrane Dryer Schematic

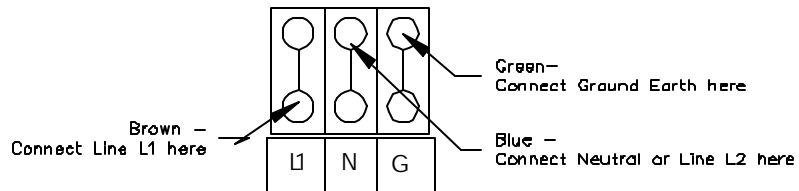

Figure 3-1 Terminal Block for Power Connections

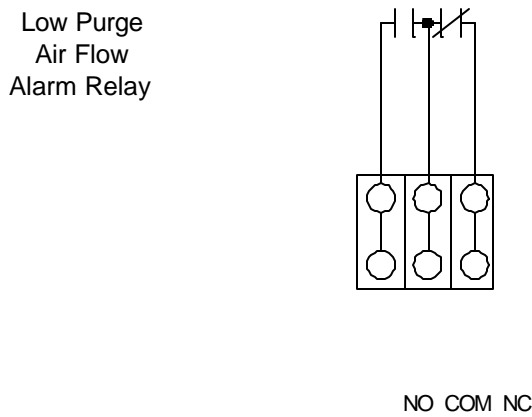

Figure 3-2 3 Pole Terminal Block for Alarm Connections

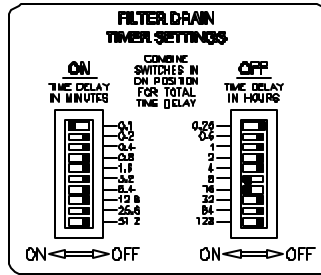
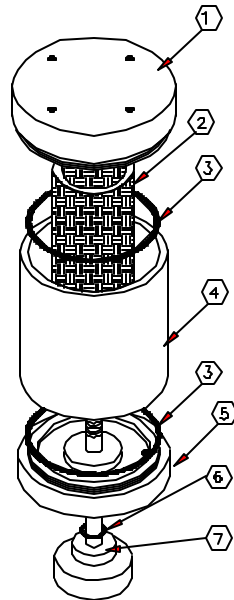

Figure 5-1 Dip Switch Layout



ITEM NO.	QTY	DESCRIPTION
1	1	TOP PIECE
2	1	FILTER CARTRIDGE
3	2	VITON O-RING
4	1	GLASS SHELL
5	1	BOTTOM PIECE
6	1	VITON O-RING
7	1	BOLT W/ POLY KNDB

Figure 6-1 FF-250 Filter